

## DCDC 600 / 192 / 14

---

This type of DCDC converter has been developed to serve as a board battery charger in electrical vehicles. It transforms main battery voltage to the value necessary to recharge a 12 V board battery. The converter logic is based on a 8bit single-chip microcontroller, which provides an optimum recharging process and a diagnostics.

### **FEATURES:**

- closed solid eloxal coated heatsink case
- forward type DCDC converter, output isolated from the input
- overheat protection - current limit decrease (no turn-off)
- short-circuit proof
- inrush current limit (NTC or relay)\*
- effective input filter
- EMC ensured\*

### **SPECIFICATIONS:**

Input voltage (nom.):	192 V
Input voltage range:	130 V – 250 V
Shutdown voltage:	125 V
Recharging characteristic:	IUOU* (see text and pictures)
Output voltage:	14 V / 14.4 V / 13.6 V (see Description)
Output current (cont.):	32 A
Output current (max.):	40 A (32A for output battery over 70Ah)
Auxiliary signalling output:	max. 5 W bulb (12 V)
Protection:	input wires - built-in fuse FF 10 A overload & short-circuit – electronic output current limit output battery - blade type Fuse-Link DIN 72581 (50 A) thermal – current limit decrease
Output voltage ripple (0 – 50 MHz):	<25 mV RMS
Line / load regulation:	<2 %
EMC - conducted emissions:	EN 55022 level A
Safety:	EN 60950
Input to case isolation:	2.0 kV AC
Output to case isolation:	500 V AC
Efficiency (cont. current, typ.):	86 %
No load current consumption:	max. 3 W
Power circuit connection: (option X6)	Input: VDFK4 terminals Output: standard screw terminals +D output: VDFK4 terminal
Ambient temperature range: (cont. current)	–25 °C .. +35 °C
Max. ambient temperature: (derated power)	50 °C
Dimensions (WxHxD):	145x90x245 mm
Weight:	2.5 kg

\* see Options.

## **DESCRIPTION:**

The microcontroller constantly measures the value of battery voltage and output current of the converter. It is able to control the converter function (battery recharging) in three basic operation modes:

- 1) converter input power switched off when leaving the vehicle
- 2) converter input power applied all the time
- 3) converter input power applied all the time, switch box auxiliary voltage (a key) utilised

Microcontroller identifies the operating mode and consequently modifies the charger function to optimize the performance.

With electrical appliances connected to the board net, the battery is recharged using IU characteristic. Basic recharging voltage level is equal to 14 V. Converter output current consists of battery recharging current and the load current drawn by appliances. When converter output current value decreases below certain level (factory set approx. to 1 A), output voltage is raised to 14.4 V. This allows to reach the full state of charge more quickly. This period is limited to 1 hour. When battery fully recharged, microcontroller either switches the charger off (option M1) or lowers its output voltage to value that can be permanently applied to battery - 13.6 V (option M2). The converter wakes up again when the output current exceeds approx. 5 A or when battery voltage falls below approx. 12.65 V.

The converter has an output for lamp located on the board control panel (max. 5 W). Normally, the lamp does not shine. It shines in case of failure or input power breakdown and flashes (on/off 2:1) when the converter is overloaded or battery deeply discharged (output voltage < 12 V).

Quiescent current value drawn by the microcontroller and the output circuit of the converter is less than 35 mA, therefore the board battery can't be discharged unexpectedly even when the vehicle not used for a long time.

## **INSTALLATION AND MAINTENANCE NOTES:**

The converter is mounted by four screws preferably vertically (wires at the bottom) or horizontally. The case must be connected to the ground of the vehicle.

We recommend to apply input power to the converter prior to connecting output battery in order to prevent high inrush current resulting from connecting output battery to discharged output capacitors. When either input power applied and/or output battery connected, microcontroller carries out several tests to determine whether converter works or not, whether battery is connected or not etc. Improper state is indicated by flashing the lamp on the board control panel. When battery is not connected within a few seconds after microcontroller starts to work, the microcontroller initialises an operating mode without battery (advanced recharging functions disabled, output voltage set simply to 14.0 V).

Because of microcontroller used it is not possible to change output voltage levels by pot (although it is physically implemented). This might affect negatively advanced recharging functions.

It's not recommended to mount the converter directly to the motor or to the gearbox. Case environmental protection must be considered in case of possible water influence.

**When connecting the converter into the vehicle electric circuitry, it is necessary to keep proper polarity (+/- poles) !**

The converter doesn't contain any moving parts, therefore no maintenance is required. It's recommended to check connector tabs and mounting screws at least once a year.

**DIMENSIONS:**

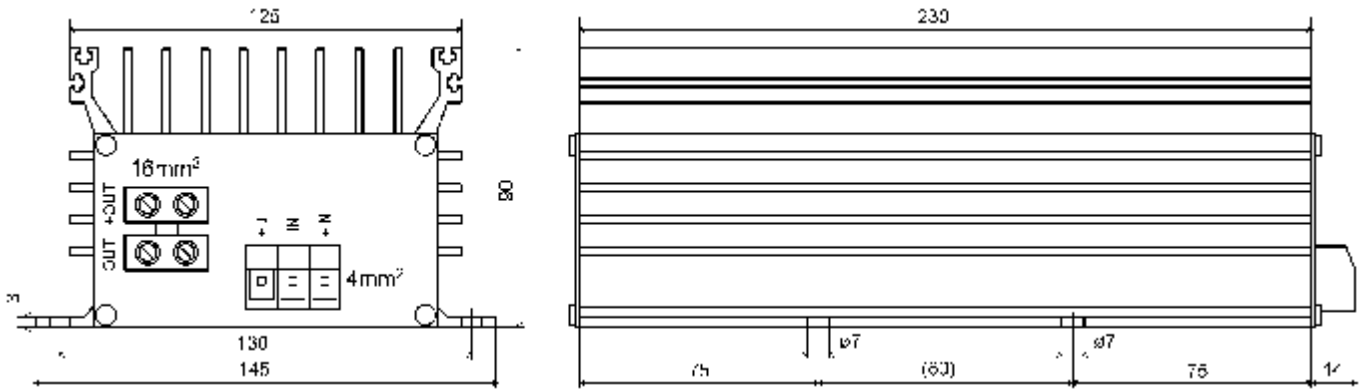

**BLOCK & WIRING DIAGRAM:**

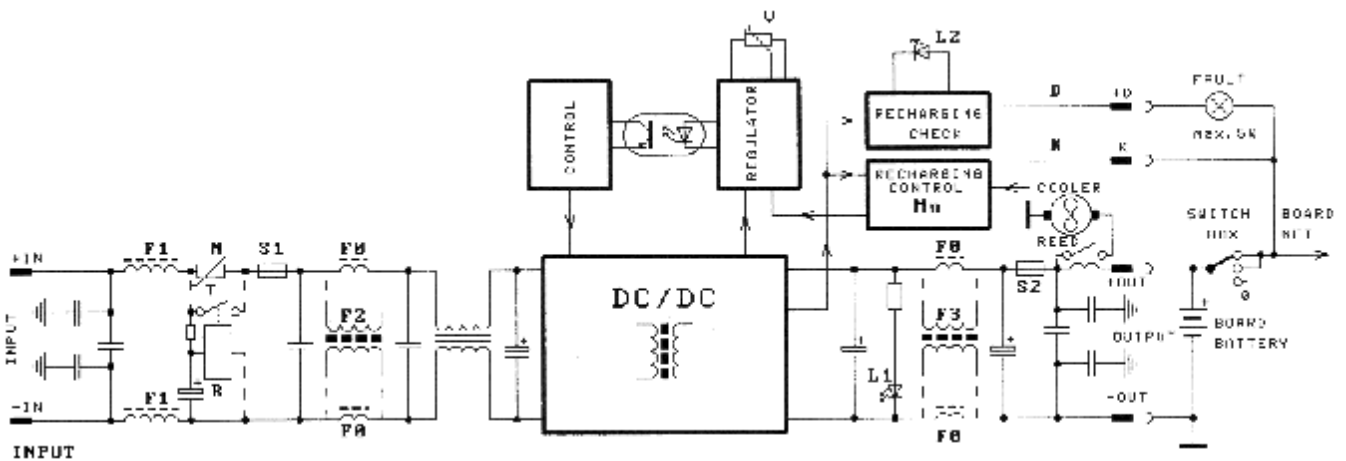

**RECHARGING CHARACTERISTIC:**

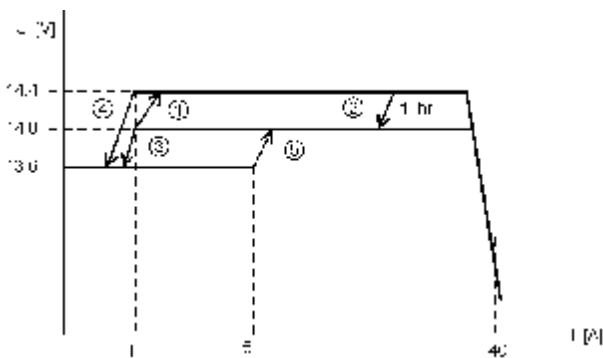

1. output voltage increased when current is lowered
2. 14.4 V limited for 1 hour
3. follows (2) when current is lowered again
4. switch-over to conservation voltage
5. wake-up and restoring initial output voltage (14 V)

On the next page time behaviour (U, I as functions of t) is shown in two characteristics which correspond to that one in U – I coordinates.

(In the first characteristic wake-up is omitted.)

All curves are simplified and idealized.

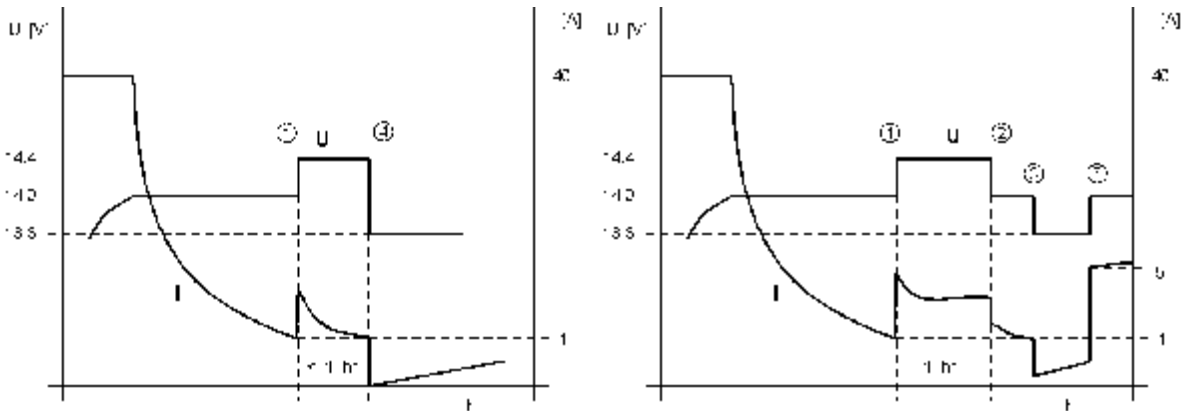

**OPTIONS:**

- Cn - Case environmental protection**
  - C0 - IP40
  - C1 - IP42 - silicon stick, moulded rubber grommet
- D - "+D" wire for charging check light (12 V, max. 5 W)**
- F2 – standard EMI suppression (EN 55022 – A), other upon customer’s request**
- Ln - Indication LED on case**
  - L1 - connected to output
  - L2 - converter work indication (independent on accu connected)
- Mn – microcontroller used for recharging process control**
  - M1 – converter switch-off when recharged (IUa characteristic)
  - M2 - conservation voltage when recharged (IUOU characteristic)
- N - NTC inrush current limit in the input**
- R - inrush current limit using a relay**
- Sn - Built-in fuse**
  - S1 - input fuse 6x32mm / 500V AC
  - S2 - output blade type Fuse-Link DIN 72581 (against reverse battery current)
- V - Pot for output voltage adjustment**
- Xn - Special requirements (connectors, mounting etc.)**
  - X0 - crimp ferrules ended wires
  - X6 – input VDFK4, output standard screw terminals 16 mm<sup>2</sup> others upon customer’s request.
- Yn - alternative colors of wires**

	+IN	-IN	+OUT	-OUT	+D	K	GND
<input type="checkbox"/> Y1	red	blue	black	brown	white	yellow	
<input type="checkbox"/> Y4	brown	blue	3xblack	3xblack			(gn.& yl.)

More details see in the block diagram.